

(No Model.)

3 Sheets—Sheet 1.

W. H. BEATLEY.

ADDING MACHINE.

No. 272,626.

Patented Feb. 20, 1883.

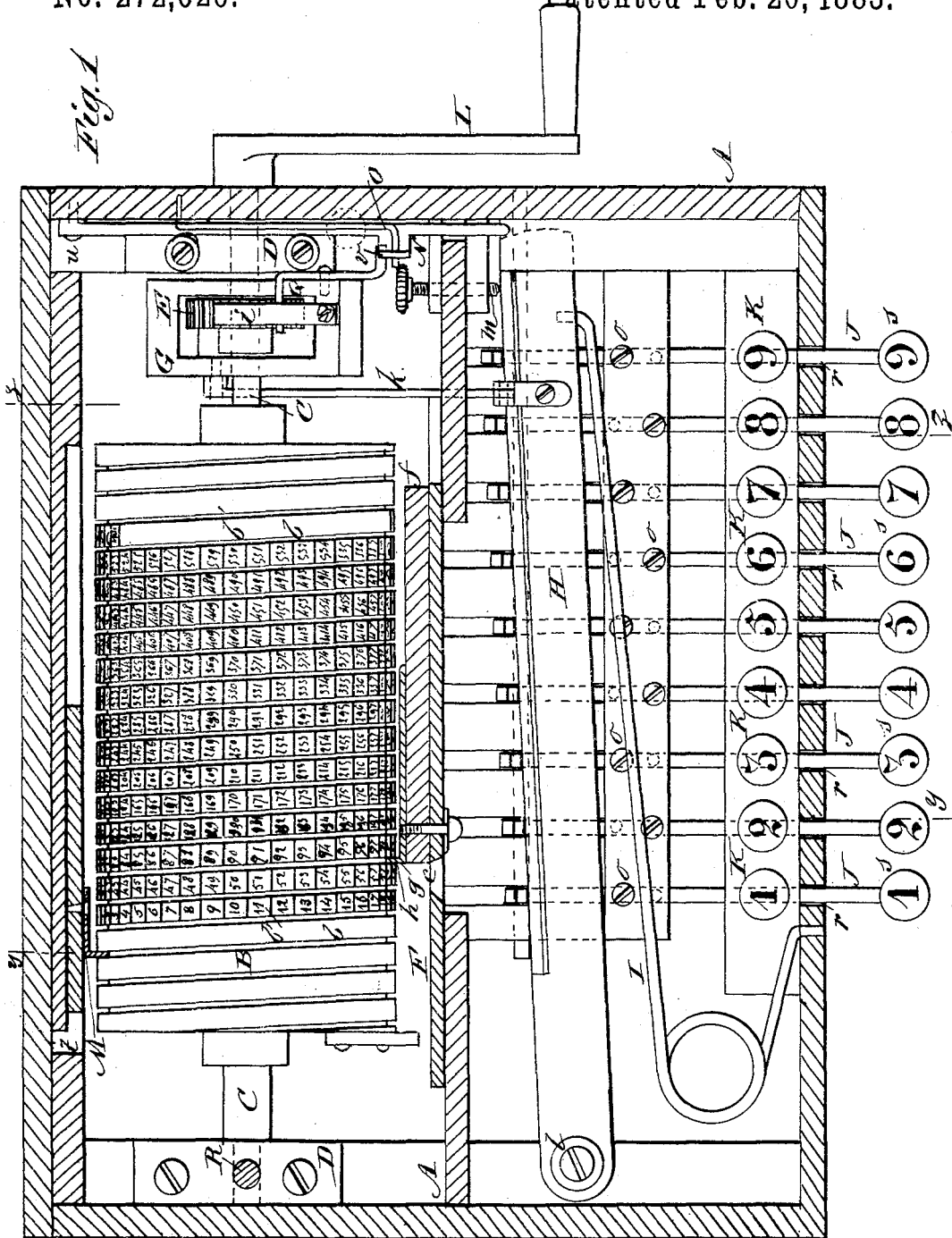

WITNESSES:

*C. Neveu*  
*C. Sedgwick*

INVENTOR:

*W. H. Beatley*  
 BY *Munn & Co*

ATTORNEYS.

(No Model.)

3 Sheets—Sheet 2.

W. H. BEATLEY.  
ADDING MACHINE.

No. 272,626.

Patented Feb. 20, 1883.

*Fig. 2*

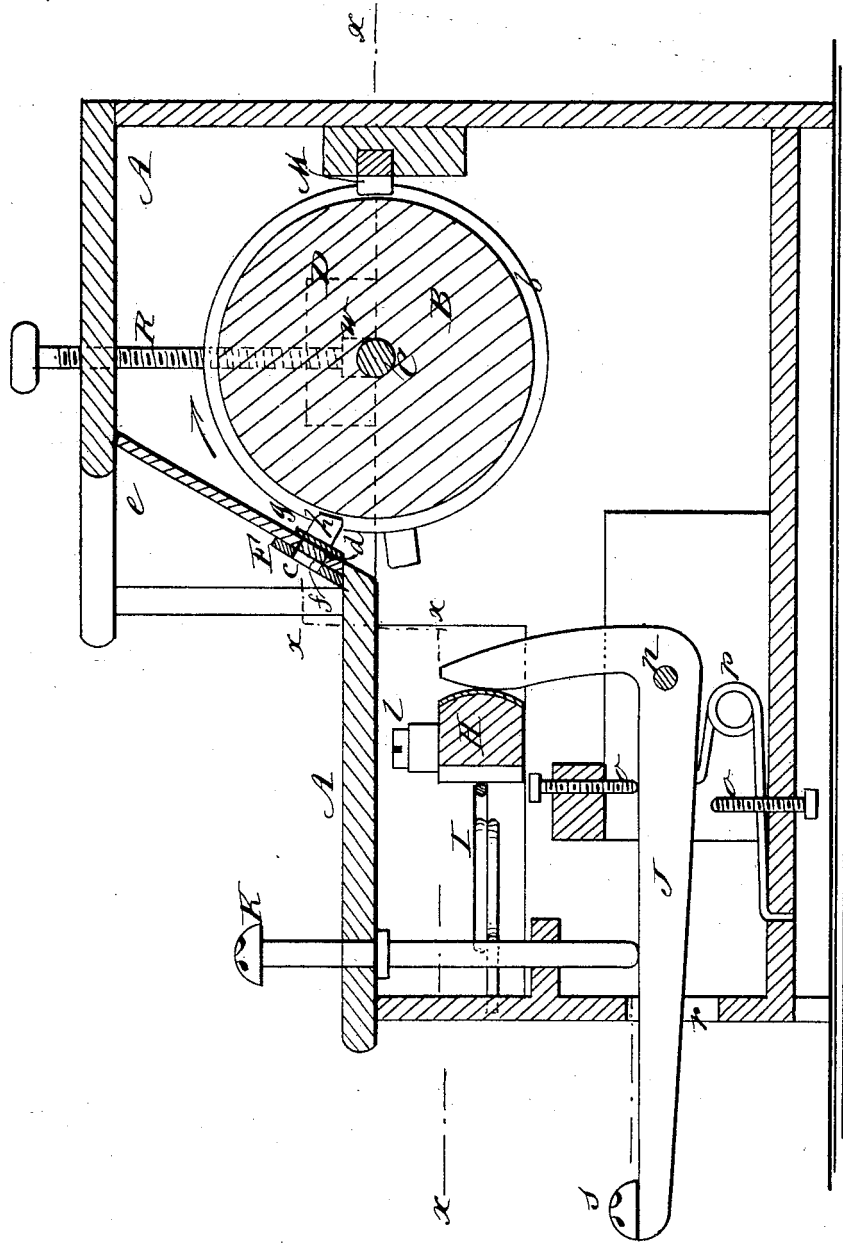

WITNESSES:

*C. N. Neveu*  
*C. Sedgwick*

INVENTOR:

*W. H. Beatley*  
BY *Munn & Co*

ATTORNEYS.

(No Model.)

3 Sheets—Sheet 3.

W. H. BEATLEY.  
ADDING MACHINE.

No. 272,626.

Patented Feb. 20, 1883.

*Fig. 3*

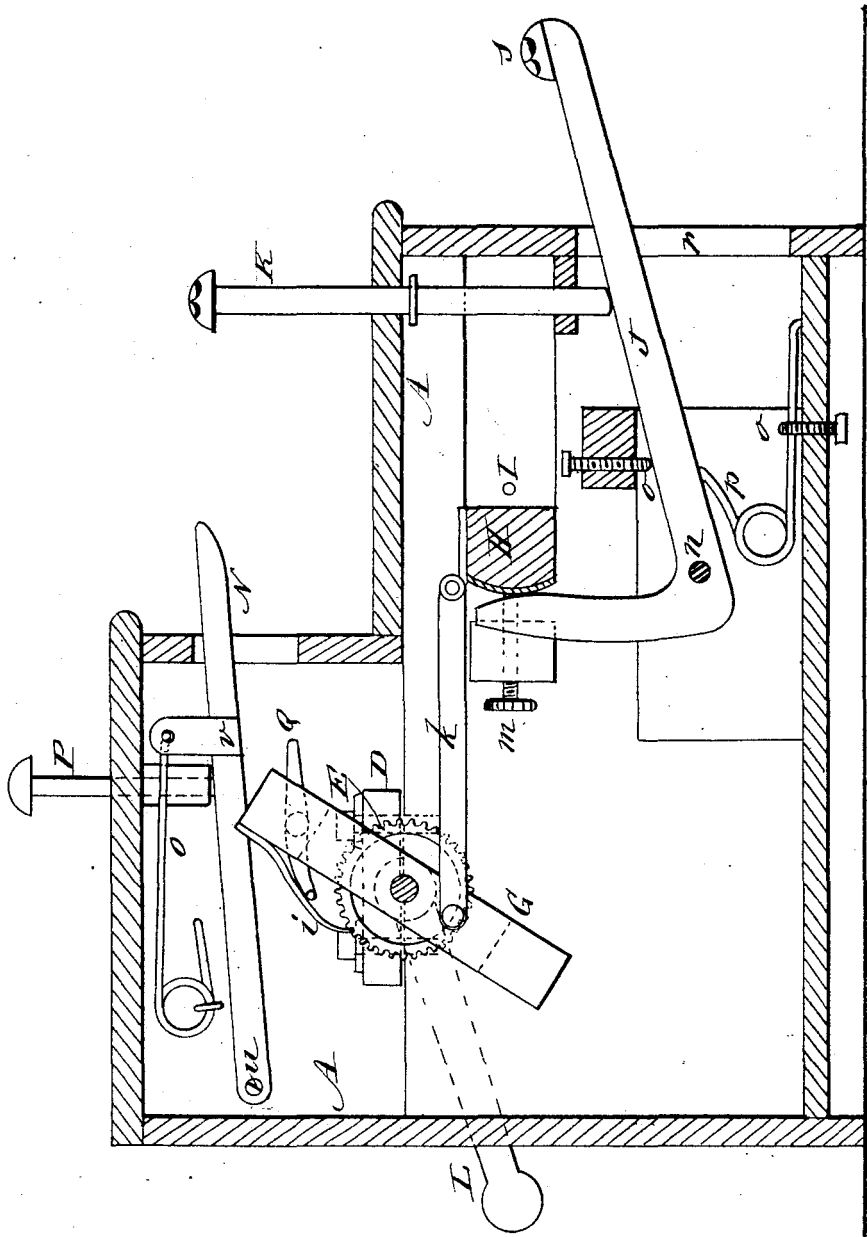

WITNESSES:

*C. Neveu*  
*C. Sedgwick*

INVENTOR:

*W. H. Beatley*  
BY *Munn & Co*

ATTORNEYS.

# UNITED STATES PATENT OFFICE.

WILLIAM HENRY BEATLEY, OF HUMANSVILLE, MISSOURI.

## ADDING-MACHINE.

SPECIFICATION forming part of Letters Patent No. 272,626, dated February 20, 1883.

Application filed November 15, 1882. (No model.)

To all whom it may concern:

Be it known that I, WILLIAM HENRY BEATLEY, of Humansville, in the county of Polk and State of Missouri, have invented certain new and useful Improvements in Adding-Machines, of which the following is a full, clear, and exact description.

This invention relates to machines for counting or adding numbers, whereby not only accuracy of addition is insured, but, by reason of the operation being a mechanical one, the mind is relieved from that exercise of thought and skill which is incidental to exclusively mental effort.

The particular kinds of adding or counting machines to which my invention belongs are those in which finger-keys denoting the addition to be made are used, and in which a spirally-grooved and numbered cylinder is rotated and caused to actuate a device provided with a sight-hole for exposing the sum totals on the cylinder of the additions as they are made.

My invention consists in certain improvements in the operating and controlling mechanism in machines of this description, whereby great simplicity, together with efficiency and accuracy, is insured.

Reference is to be had to the accompanying drawings, forming part of this specification, in which similar letters of reference indicate corresponding parts in all the figures.

Figure 1 represents a horizontal section, taken mainly as indicated by the irregular line *xx* in Fig. 2, of an adding-machine embodying my invention. Fig. 2 is a transverse vertical section of the same on the irregular line *yy* in Fig. 1, and Fig. 3 a further transverse vertical section of the machine on the irregular line *zz* in Fig. 1.

A in the drawings indicates the box or case of the machine, which contains and carries the working parts.

B is the adding-cylinder, arranged to occupy a horizontal position within the case, and of any desired length and diameter. This cylinder, which may be of wood or any other suitable material, has its periphery divided into any number of equal parts, which may be separated by lines running lengthwise of the cylinder, and these lines or divisions be intersected by a spiral groove, *b*, arranged around

the cylinder. The spaces *b'* thus formed on the peripheral surface of the cylinder by the longitudinal lines or divisions and the intersecting spiral groove are numbered consecutively from 1 upward, beginning at the left-hand end of the cylinder and following in regular order in the course of the spiral groove. Said cylinder B is rigidly secured upon a horizontal shaft, C, that works in bearings D D in the ends of the case, and which has firmly fastened to it near its one or right-hand end a ratchet or other toothed or notched wheel, E, the number of teeth or divisions on which correspond with the number of longitudinal divisions or rows of divisions made on the periphery of the cylinder B.

To give a distinct reading of the numbered surface of the cylinder, it is or may be painted white on its periphery, and the longitudinal lines on it and crossing the spiral groove *b* be made in black, and the figures which follow in regular numerical order, as hereinbefore described, and which occupy the spaces *b'*, may also be made in black or any suitable color. Only one of these numbered spaces is visible at a time from the exterior of the case, the same being seen through a sight-hole, *c*, made in a longitudinal slide, F, which covers and extends beyond a longitudinal slot, *d*, of the same or not less length than the numbered surface of the cylinder which it faces. This slot *d* is made in the back of a recessed portion, *e*, of the front upper board of the case, which back may be set inclining upwardly in a rear direction, and the slide F, which works through the ends of said recessed portion, be set similarly inclining on the outside face of said back to give a better light and facilitate exposure of the numbered surface of the cylinder B through the sight-hole *c* in the slide. Said slide F is backed for a portion of its length by a guiding-bar, *f*, which works in the slot *d*, and attached to the rear side of this bar *f* is a plate, *g*, having a projection, *h*, by which the slide F is engaged with the spiral groove *b* of the cylinder B.

The machine is designed to stand on a table or desk in front of the operator, and when being worked the direction of rotation of the cylinder B on its upper surface is away from the operator. Said cylinder is actuated by a rock-

ing ratchet beam or lever, G, loose upon the shaft C, and having an attached spring-pawl, *i*, which engages with the wheel E on said cylinder-shaft. The ratchet-beam G is connected  
5 on the opposite side of its axis to that of the pawl *i* by a rod, *k*, with a horizontally-swinging lever, H, extending lengthwise of the machine in front of the cylinder B, and working on a pivot, *l*, at one end, while its other or free  
10 end is forced by a spring, I, against an adjustable screw-stop, *m*, which gives the pawl *i* a fixed and proper starting-point on the wheel E.

To actuate the cylinder B, the horizontal lever H is moved away from it against the pressure of the spring I, and this is done by pressing down on the forward or horizontal arm of any one of nine bell-crank keys or levers, J, arranged to work on pivots *n*, and having upper arms which bear against the back of the lever H to draw it forward, and thereby give motion to the cylinder B. These bell-crank levers J have their motion limited by adjustable stops or screws *o* to insure their exact action in controlling the motion of the cylinder B, and after  
25 being pressed down by the finger are returned to their normal position by springs *p*. Said levers have a different range or extent of motion to give the lever H different lengths of stroke, in order that the pawl *i* may move the wheel E, and cylinder B different distances. This variation in stroke of the levers J is progressive, beginning, say, with the farthestmost left-hand lever J, which, when its forward arm is pressed down by the finger, will move the wheel E one  
35 tooth and the cylinder B one of its numbered spaces circumferentially. The next lever J, when operated, has a longer action and moves the cylinder B two spaces, while the third lever J from the left-hand side of the machine, when operated, moves the cylinder B three spaces, and so on successively for each of the remaining levers J, each increasing the movement of the cylinder B in like proportion and manner till the last lever J on the right-hand  
45 side is reached, which lever moves the cylinder B nine numbered spaces at a time. These levers J may be constructed so that their lower arms project through slots *r* in the front of the case, and their outer ends each be mounted with a button, *s*, which buttons may be numbered to indicate the range of motion of the levers. When thus constructed said levers may be used directly as the keys by which the machine is operated, or they may be depressed  
50 by numbered push-pins K from the top of the front portion of the case, when, if desired, the levers J need not project through the front of the case.

To add by the machine, the cylinder B is first set or adjusted so that a space on it immediately preceding (in course of the spiral groove *b*) figure 1 thereon, and which may or may not have an arbitrary mark, is brought opposite the sight-hole *c* in the slide F, which then will  
65 be at the end of its extreme movement to the left. The key or lever J representing and corresponding with the first figure in the column

to be added is then pressed down, which will move the cylinder B so as to bring a like figure on it opposite the sight-hole *c* in the slide  
70 F, after which the key corresponding to the next figure in the column is operated, which will expose a figure on the cylinder equal to the sum of the two first figures in the column, and so on until the entire column is added,  
75 when the aggregate will be seen upon the cylinder on looking through the sight-hole *c* of the slide for the purpose, it not being necessary until the addition of the column is completed to inspect the figures made visible on  
80 the cylinder. A note is then taken of the resultant or right-hand figure of the sum of the added column, and the machine run back or reversed to bring the numbers on the cylinder B and slide F back to their starting position,  
85 after which the operation is started afresh by pressing on the key that represents the figure to be carried, or first figure in the next column, as the case may be, and proceeding to add by the machine as before, and so on for any number  
90 of columns. To reverse or run back the cylinder B, the pawl *i* is first lifted from its engagement with the wheel E and the shaft C rotated by means of a crank, L, which the operator turns toward him, or in a reverse direction to the previous motion of the cylinder.  
95 This is done until a stop-slide, M, in gear with the groove *b* on the back side of the cylinder B, comes in contact with a stop, *t*, when the numbers on the cylinder and the slide F, as regards its sight-hole *c*, will be returned to their normal position.  
100

The means used for releasing or tripping the cylinder consist, in part, of a lever, N, pivoted at *u* to one end of the case, and provided  
105 with a projection, *v*. This lever may be arranged to project through a slot in the upper front portion of the case, to admit of its being pressed down directly by the finger of the operator against the pressure of a spring, O; or said lever may be thus operated indirectly  
110 by pressing down on a push-pin, P. Pivoted to the ratchet-lever G is a dog, Q, which, when the lever N is held raised by the spring O, is prevented from coming in contact with the projection *v* during the vibration of the ratchet-lever in working the machine, but which dog, when the lever N is pressed down, is actuated by the projection *v* and caused to trip or disengage the pawl *i* from the wheel E.  
120

To insure accuracy it is very important that in the working of the machine there should be no slip of the cylinder B, either by the momentum given it when operating it by the pawl *i* or by friction of said pawl and ratchet-lever G in the back motion of the pawl. This might be secured, for a limited time at least, by tightening down the caps of the bearings in which the shaft C works, so as to produce a given friction or resistance to the cylinder; but a much more convenient and readily-adjustable means is provided in the shape of a friction brake or clamp consisting of a screw, R, adjustable from the exterior or outside of  
130

the top of the case, and provided with a friction foot or block, *w*, arranged to bear down on the shaft *C* of the cylinder.

Having thus described my invention, I claim as new and desire to secure by Letters Patent—

5 1. The combination, with the spirally-grooved adding-cylinder *B* and the sight-hole slide *F*, actuated thereby, of the lever *H*, the spring *I*, the bell-crank levers or keys *J*, the springs *p*,  
10 the ratchet lever or beam *G*, the pawl *i*, the wheel *E*, the shaft *C*, and the rod or connection *k*, substantially as specified.

2. The combination, with the spirally-grooved adding-cylinder *B*, of the sight-hole slide *F*,  
15 arranged to engage with the spiral groove in said cylinder, and having its face set inclining upwardly in a rear direction, whereby a better sight of the exposed number or figure on the cylinder from the front of the machine is obtained,  
20 essentially as described.

3. The regulating-screws *o o*, in combination with the bell-crank levers *J*, the lever *H*, the adding-cylinder *B*, and mechanism for communicating motion from said lever *H* to said cylinder,  
25 substantially as specified.

4. The combination, with the spirally-grooved adding-cylinder *B* and sight-hole slide *F*, actuated thereby, of the stop-slide *M*, arranged to engage with the spiral groove in the cylinder, and the stop *t*, substantially as and for the  
30 purposes specified.

5. The adjusting-screw *m*, in combination with the lever *H*, the spring *I*, and the pawl-and-ratchet mechanism operated by said lever,  
35 essentially as described.

6. The combination, with the adding-cylinder *B*, ratchet-wheel *E*, pawl *i*, and ratchet-lever *G*, of a tripping mechanism consisting of the lever *N*, having a projection, *v*, the spring *O*, and the dog *Q*, pivoted to the lever  
40 *G*, substantially as specified.

7. The combination, with the adding-cylinder *B*, its shaft *C*, and mechanism for intermittently operating said cylinder, of the screw friction-clamp *R w*, essentially as and for the  
45 purpose herein set forth.

WILLIAM HENRY BEATLEY.

Witnesses:

SAMUEL B. EVANS,

JOHN B. BARNETT.